

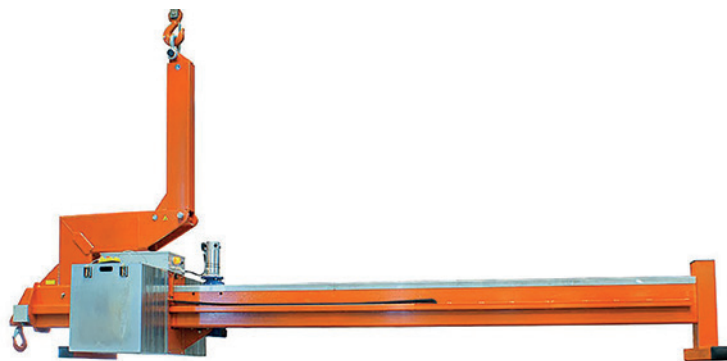

## OPERATORS MANUAL

# COUNTERBALANCE LIFTING BEAM CBL6300



**Northern** (Head Office)  
Tel: +44 (0)1482 227333

**Central**  
Tel: +44 (0)1302 341659

**Southern**  
Tel: +44 (0)203 174 0658

	Page
<b>Table of contents</b>	<b>2</b>
<b>1 General information on the counterweight balancer</b>	<b>4</b>
1.1 Manufacturer's information	4
1.2 Service workshop	4
1.3 Scope of application	4
<b>2 Proper use of the counterweight balancer</b>	<b>5</b>
2.1 Functional principle, use and safety concept	5
2.2 Safety instructions	5
2.3 Symbols and markings	6
2.4 Structure of the counterweight balancer	8
2.5 Operating conditions and restrictions	9
2.6 Functional dimensions of the counterweight balancer	9
2.7 Transport and storage	10
<b>3 Instructions for using the counterweight balancer</b>	<b>11</b>
3.1 Electrical power supply	11
3.2 Control of the counterweight balancer	12
3.3 Preparation of the counterweight balancer	12
3.4 Inclination of the counterweight balancer	13
3.5 Stop plate and yellow signal light	14
3.6 Start-up	14
3.7 Handling of construction elements	15
<b>4 Service and maintenance</b>	<b>16</b>
4.1 General remarks	16
4.2 Mechanical system	16
4.3 Electrical and electronic components	17
<b>5 Handling incidents</b>	<b>19</b>
<b>6 Disposal and recycling</b>	<b>19</b>
<b>Annex 1:</b> EC Declaration of Conformity	
<b>Annex 2:</b> Inspection tag according to directive 2006/42/EC	
<b>Annex 3:</b> Electrical Circuit Diagram	

---

	Page
<b>Table of figures</b>	3
Fig. 1: Counterweight balancer GGA-B 6300/40/3,0/6,0 oVH	8
Fig. 2: Attachment GGA-B 6300/40/3,0/6,0 oVH	9
Fig. 3: Functional dimensions of the counterweight balancer	9
Fig. 4: Transport and storage of the counterweight balancer	10
Fig. 5: Charge indicator	11
Fig. 6: Cable remote control	12
Fig. 7: Assembled counterweight balancer	13
Fig. 8: Inclination of the counterweight balancer	13
Fig. 9: Stop plate and yellow signal light	14
Fig. 10: Battery charger (example)	17

## 1 General information on the counterweight balancer

### 1.1 Manufacturer's information

Manufacturer's name and registered office:

WIRTH GMBH  
Vacuum Lifting Technology Division  
Brehnaer Straße 1  
D-06188 Landsberg

Device characteristics:

Product description:	Counterweight balancer
Type:	GGA-B 6300/40/3,0/6,0 oVH
Serial number:	(see type plate)
Year of manufacture:	(see type plate)
Weight:	ca. 1050 kg (without counterweight) ca. 3050 kg (with 40 pieces counterweights) 1 piece counterweight = ca. 50 kg
Working Load Limit:	see section 2.3 Symbols and markings
CE mark:	according to EC Declaration of Conformity Annex 1
Inspection tag attached to the device according to Annex 2.	

### 1.2 Service workshop

WIRTH GMBH	Telephone: +49 (0) 34 602 / 70 88 - 0
Brehnaer Str. 1	Fax no.: +49 (0) 34 602 / 70 88 - 111
D-06188 Landsberg	E-mail: <a href="mailto:info@wirth-gmbh.com">info@wirth-gmbh.com</a>

### 1.3 Scope of application

The operating instructions on hand represent the state-of-the-art and the safety measures defined by the European Machinery Directive valid at the editing date of the manual.

Diverging or amending national regulations may not have been taken into consideration.

The user is exclusively responsible to observe such supplementary or deviating regulations.

## 2 Proper use of the counterweight balancer

### 2.1 Functional principle, use and safety concept

The counterweight balancer GGA-B 6300/40/3,0/6,0 oVH is a load lifting attachment. It is used for the lifting and positioning of construction elements with integrated crane eye in difficult to access areas (e.g. eaves). Motor-driven counterweights enable to equilibrate the load. Specific safety requirements, which have been taken into account during construction, execution, technical documentation and in drawing up the operating instructions, result from the function of the counterweight balancer being a load lifting attachment.

Therefore, strict adherence to the instructions and information for proper and safe use given in the operating manual is a prerequisite for the manufacturer's warranty during the stipulated warranty period.

Combining the counterweight balancer with a hoist is the responsibility of the user of the counterweight balancer. The user himself is responsible for proper implementation of the relevant guidelines and instructions. The instructions given in this operating manual by the manufacturer of the counterweight balancer are considered to be additional support.

Prior to initial start-up, the suitability of the combination hoist/counterweight balancer in operating conditions has to be checked by skilled personnel.

Furthermore, the counterweight balancer has to undergo regular inspections by an expert (see point 4.1). An expert is a person that due to their technical training and experience has sufficient knowledge in the area of load lifting attachments and is familiar with relevant occupational and safety instructions, regulations and generally recognized codes of practice which enables them to assess operational safety of load lifting attachments.

The initial inspection of the combination hoist/counterweight balancer as well as the successful performance of the annual inspection of the counterweight balancer by an expert has to be documented.

The counterweight balancer's manufacturer offers expert inspections as a service and documents the inspections on the counterweight balancer by placing the inspection tag on the inspection card according to Annex 2 indicating the next inspection date.



For further information please contact us or visit our website at [www.wirth-gmbh.com](http://www.wirth-gmbh.com).

### 2.2 Safety instructions

- (1) Only employ **cranes** that **have a sufficient Working Load Limit** in all possible working positions. Please take into account that the load to be lifted consists of the weight of the counterweight balancer, the weight of the construction element to be handled and, if applicable, the weight of the lifting accessory!
- (2) **Never use a** damaged, not fully functional or not complete counterweight balancer!
- (3) Prior to initial start-up **have an expert check and document** the combination crane/counterweight balancer!
- (4) Only operate the crane with an **operating license!**
- (5) Only operate the combination crane/counterweight balancer if you are familiar with **the control and display elements as well as the operating manuals**. You have to know how the functions affect the entire installation!
- (6) **Prior to using** crane and counterweight balancer check the function of the **control and display elements** as well as **the warning devices!**
- (7) **Never stand or walk under the suspended load!**

- (8) Make sure that **nobody climbs** the counterweight balancer and the suspended load and **tries to ride along**.
- (9) In case of **malfunctioning** and maintenance work, turn the counterweight balancer off.
- (10) Never employ the counterweight balancer in **explosive areas or in the area of aggressive media!**
- (11) Only work at wind speeds **less than 30 km/h**, otherwise you risk uncontrollable swinging of the load!
- (12) **Do not lift** the load **higher than necessary!**
- (13) **Always** wear suitable protective clothing, helmets, gloves and safety shoes, in order to avoid for example crush and cut injuries!
- (14) **Never** leave the lifted load unsupervised!
- (15) Comply with the stipulated **maintenance information**:
  - **daily visual and functional inspection** of the control elements!
  - depending on the operating conditions, **but at least annually**, inspection by an expert!
- (16) Never modify the counterweight balancer in a way that its safety is impaired. **Otherwise the manufacturer's warranty will be void!**
- (17) Do not remove information signs, safety pictograms and inspection tags from the counterweight balancer! **Otherwise the manufacturer's warranty will be void!**

### 2.3 Symbols and markings

Signal word	Meaning	Consequences of non-compliance
 <b>DANGER</b>	Warns of imminent threat of danger	Death or serious injury or substantial material damage as consequence.
 <b>WARNING</b>	Warns of potential threat of danger	Death or serious injury or substantial material damages are possible.
 <b>ATTENTION</b>	Warns of possibly dangerous situation	Light injury or material damages are possible.

Next to the type plate the following safety-related signs and pictograms are attached to the counterweight balancer:



(Before operating, read and comply with the operating manual as well as safety instructions!)

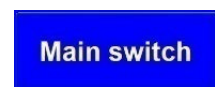
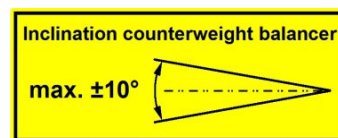

(General information)

Working Load Limit (WLL) Counterweight Balancer		
Overhang		WLL
1,50 m	.....	6300 kg
1,75 m	.....	5050 kg
2,00 m	.....	4150 kg
2,25 m	.....	3400 kg
2,50 m	.....	2850 kg
2,75 m	.....	2350 kg
3,00 m	.....	1950 kg

(Working Load Limit)



(Attachment point  
crane hook)



(Beware of hand  
injury)



(Warning of hazardous  
electrical voltage)



(Beware of hand injury)

Inspection card in accordance with Annex 2

(Inspection card)

## 2.4 Structure of the counterweight balancer

The functional main assemblies of the counterweight balancer are (s. fig. 1):

- the crane eye (1), for attaching the counterweight balancer to the crane,
- the load hook counterweight balancer (13), for attaching the load,
- the travelling cage (18) with counterweights (17), for equilibrating the load,
- the cable remote control (12), for operating the travelling cage and the main switch (10) for switching the counterweight balancer on and off.

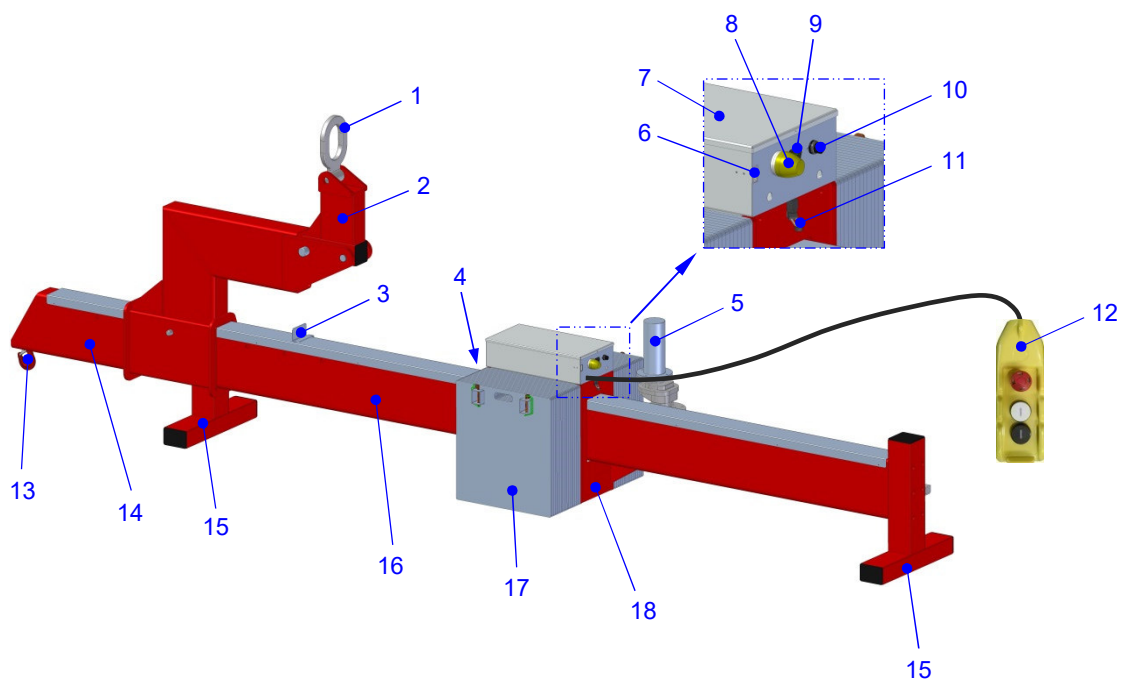

Fig. 1: Counterweight balancer GGA-B 6300/40/3,0/6,0 oVH

1	Crane eye	10	Main switch
2	Crane arm	11	Back limit switch
3	Stop plate	12	Cable remote control
4	Front limit switch	13	Load hook counterweight balancer
5	Travelling drive travelling cage	14	Overhang
6	Battery charging socket	15	Base
7	Cover	16	Main girder
8	Signal light yellow	17	Counterweight
9	Charge indicator	18	Travelling cage



The counterweight balancer GGA-B 6300/40/3,0/6,0 oVH is designed as a load lifting attachment and is mounted to a crane according to fig. 2.

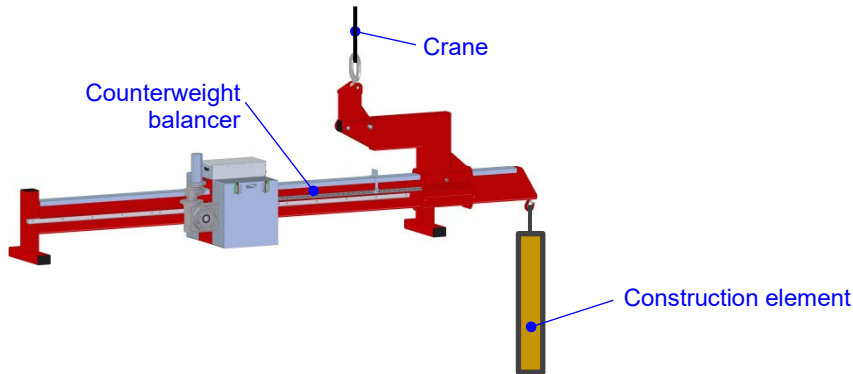

Fig. 2: Attachment GGA-B 6300/40/3,0/6,0 oVH

## 2.5 Operating conditions and restrictions

The counterweight balancer GGA-B 6300/40/3,0/6,0 oVH may only be operated by instructed personnel.

Ambient temperature has to be at least 0 °C and must not exceed 40 °C (applies only to 1013 mbar and sea level). The capacity of the installed batteries is reduced with low temperatures. The airborne sound emitted by the counterweight balancer is less than 70 dB(A), so that no special protective measures are required.

Operating restrictions result from the Working Load Limit of the counterweight balancer (s. section 2.3 Symbols and markings) as well as the performance data of the crane used and the construction site conditions.

Using the counterweight balancer in combination with a vacuum lifting device is not permitted!

## 2.6 Functional dimensions of the counterweight balancer

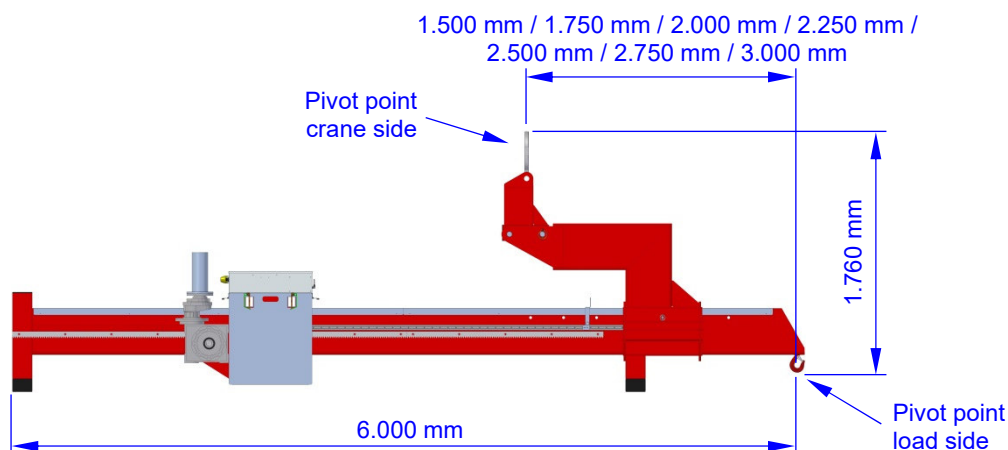

Fig. 3: Functional dimensions of the counterweight balancer

Due to the arrangement of the crane side's and load side's pivot point as well as the vertical distance of both pivot points from one another, the counterweight balancer has a positive position of stability. Thus, it is always stable.

## 2.7 Transport and storage

The counterweight balancer may be moved only by a suitable hoisting device/means of transport of appropriate Working Load Limit.



**For transport purposes take the counterweight balancer out of operation! To this end turn the main switch to position OFF and, if applicable, disconnect the battery charger!**



**In order to avoid damage to the batteries due to deep discharge during storage, the counterweight balancer has to be charged at least every two weeks.**



**If necessary, conserve the counterweight balancer in order to prevent damages to the device when storing it for a longer period of time.**

For storage purposes, the height of the counterweight balancer can be reduced to approx. 1270 mm. Perform the following steps successively in order to reduce the height of the counterweight balancer:

1. Place the counterweight balancer on a flat, solid ground.
2. Bring the counterweights in the position shown in fig. 4.
3. Remove the locking bolt B with lynch pin type 2 (s. fig. 7).
4. Fold the crane arm in the position shown in fig. 4.

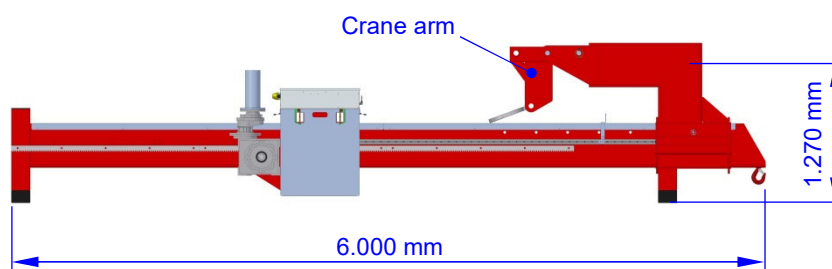

Fig. 4: Transport and storage of the counterweight balancer

### 3 Instructions for using the counterweight balancer

#### 3.1 Electrical power supply

Electrical power is supplied by a battery 24 V / 60 Ah (two 12 V batteries in line).

The charge level of the battery is monitored by a charge indicator according to figure 5. Light-emitting diodes (LED) in the signal colours green, yellow and red indicate the current charge level after the counterweight balancer has been switched on.

The charge indicator shows the following charging states:

- ⇒ If one of the green LEDs lights up, the battery is charged. The counterweight balancer is ready for use.
- ⇒ If the third LED from the left (yellow LED) lights up, the battery should be charged.
- ⇒ If the second LED from the left (yellow LED) lights up, or if the second LED (yellow LED) from the left and the red LED light up in turns, the battery has to be charged without delay, in order to avoid deep discharge and potential damages.

The charge indicator is arranged on the counterweight balancer as per fig. 1.

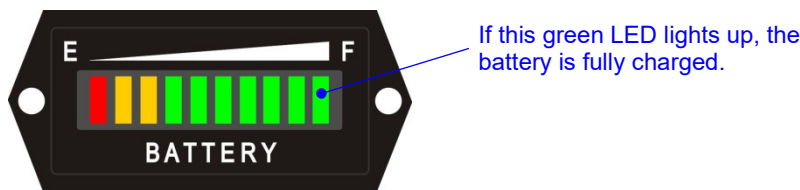

Fig. 5: Charge indicator



**Do not use the counterweight balancer, if the yellow LED is flashing, or the yellow and red LED are flashing alternately. Possibly suctioned loads shall be lowered. The counterweight balancer has to be charged instantly in order to avoid deep discharge and by that possible damage to the battery.**



**The user has to ensure that the battery is properly charged when operating the counterweight balancer.**



**The charge indicator only shows the current voltage level of the battery. It does not give any reliable information regarding the batteries' capacity.**



**The charge indicator responds rather slowly. In order to assess the voltage level realistically after the charging process (s. point 4.3) you have to move the travelling cage of the counterweight balancer for approximately 2 minutes, and then use the indicated charge level of the battery as a basis for assessing how to employ the counterweight balancer.**

### 3.2 Control of the counterweight balancer

The counterweight balancer is operated by a cable remote control according to fig. 6.

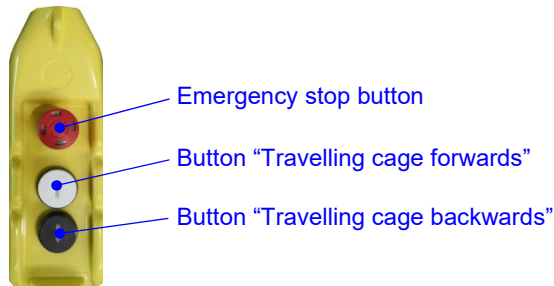

Pushing the emergency stop button immediately stops the movement of the travelling cage.

Fig. 6: Cable remote control

### 3.3 Preparation of the counterweight balancer

Perform the following steps successively in order to **assemble** the counterweight balancer:

- ⇒ Place the counterweight balancer on a solid, even ground.
- ⇒ If the crane arm is in transport position (s. fig. 4), fold it into the position shown in figure 7 by performing the following steps:
  1. Fold the crane arm into the position shown in figure 7.
  2. Mount locking bolt B supplied with the delivery. Secure the locking bolt B by means of the lynch pin type 2 that was also supplied with the delivery.
- ⇒ Adjust the required overhang by performing the following steps:
  1. Remove the locking bolt A.
  2. Push the crane arm to the required position.
  3. Mount the previously removed locking bolt A. Secure the locking bolt by means of the lynch pin type 1.
- ⇒ Install a number of counterweights that corresponds to the load to be lifted and the selected overhang. To this end perform the following steps:
  1. Remove the four lynch pins type 3 (s. fig. 7).
  2. Take the counterweights from or push the counterweights onto the rectangular tubes of the travelling cage. Make sure that there is always the same number of counterweights on each side of the travelling cage! *Notes:*
    - Two of the 40 counterweights differ in their form of the other ones. Push each of them at first on the rectangular tubes (1x left, 1x right).
    - Using less than 40 pieces of the counterweights results in reduced Working Load Limits compared to the values that are stipulated on the decal indicating the Working Load Limits!
  3. Mount each of the previously removed lynch pins type 3 as close as possible to each of the outermost counterweights. This is the only way to ensure that the counterweights do not slip or even slide off the rectangular tubes during operation or transport.
- ⇒ Position the stop plate (s. fig. 9) as follows:  
 Release the wing screw of the stop plate, push the stop plate as far as possible in the direction of the load hook and retighten the wing screw.



**Only use the counterweight balancer if its crane arm is completely secured using the fasteners supplied with the delivery!**



**Make sure that the mounted counterweights are secured to the travelling cage by means of four lynch pins type 3 after assembly/disassembly of the counterweights!**

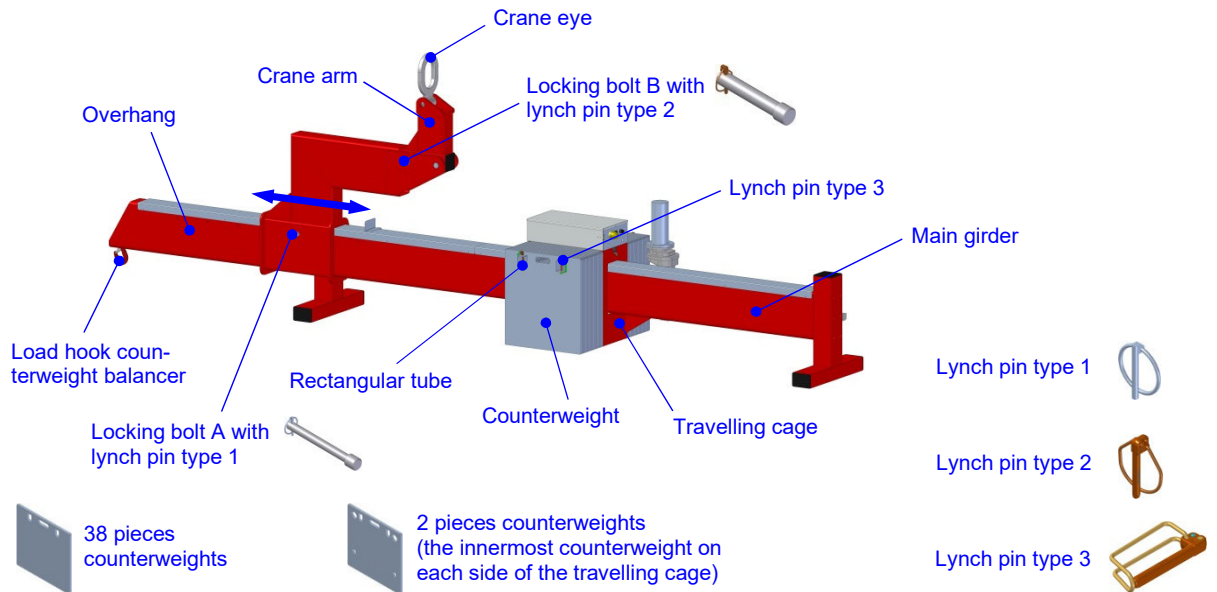

Fig. 7: Assembled counterweight balancer

### 3.4 Inclination of the counterweight balancer

The movable counterweights enable to equilibrate the counterweight balancer, if applicable, including a suspended load. Due to safety-related aspects, the inclination angle of the main girder is limited to  $\pm 10^\circ$  by sensors. If the main girder reaches  $\pm 10^\circ$  of inclination, the travelling cage with the counterweights stops. It can then only be moved in the opposite direction.

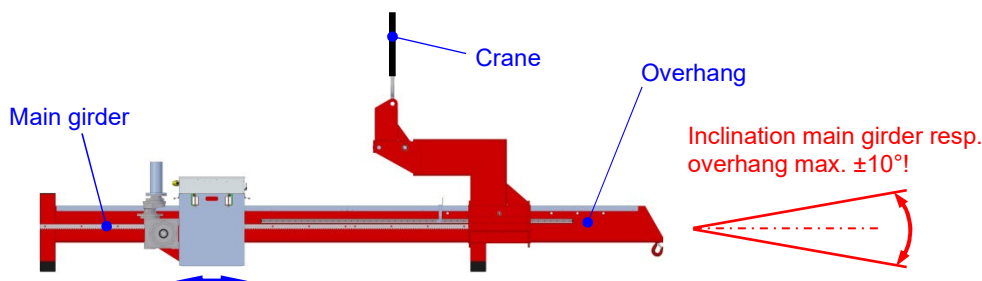

Fig. 8: Inclination of the counterweight balancer



**By moving the counterweights, make sure that the main girder of the counterweight balancer is always equilibrated! The maximum admissible angle deviation is  $\pm 10^\circ$ .**

### 3.5 Stop plate and yellow signal light

Equilibrating the counterweight balancer that was equipped with an appropriate number of counterweights depending on the load to be lifted, marking the corresponding position of counterweights by adjusting the stop plate on the front limit switch of the travelling cage and extinguishing of the yellow signal light when this position is reached, ensure that the main girder is equilibrated at the moment the load is released. Thus, sudden forwards or backwards tilting of the counterweight balancer is prevented.

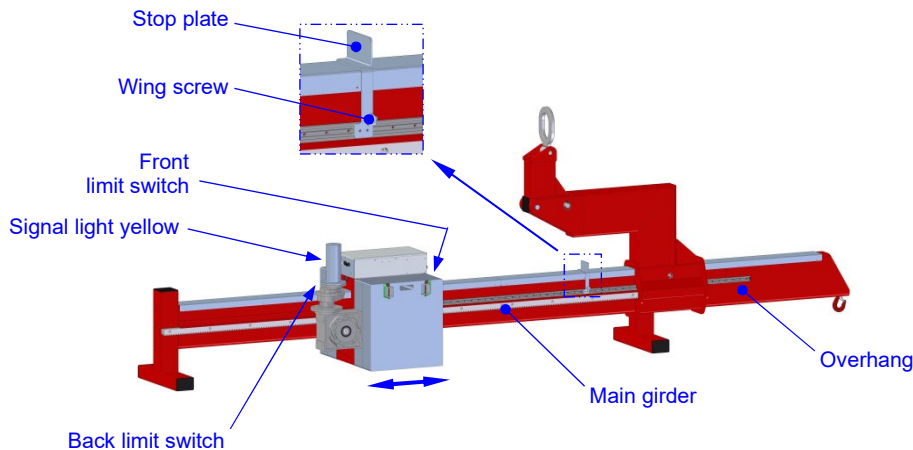

Fig. 9: Stop plate and yellow signal light

*Note:*

The yellow signal light is coupled to the front limit switch of the travelling cage, i.e. the signal light extinguishes if the limit switch is triggered by approaching the stop plate or manually, when the counterweight balancer is switched on. However, the signal light remains active, if the limit switch is not triggered.

### 3.6 Start-up

In order to start-up the counterweight balancer, proceed as follows:

- Turn the main switch of the counterweight balancer to position "ON".
  - ⇒ The yellow signal light on the travelling cage is illuminated.  
If this is not the case, check if the signal light was turned off by contact of the front limit switch of the travelling cage with the stop plate. In this case, check if the yellow light is activated by moving the stop plate.
- Check the batteries' charge level on the charge indicators:
  - ⇒ if the green LED lights up, the device is ready for operation,
  - ⇒ if the second LED from the left (yellow LED) flashes or the second LED from the left (yellow LED) and the red LED light up in turns, the battery needs to be charged!

### 3.7 Handling of construction elements

Prior to the grabbing of construction elements:

- ⇒ the counterweight balancer has to be prepared according to point 3.3 of this operating manual and following this, it has to be coupled to the crane (s. fig. 2).
- ⇒ the counterweight balancer has to be started-up according to section 3.6.



**Always lift the counterweight balancer slowly and carefully using the crane. Equilibrate them by moving the travelling cage while lifting!**



**When handling loads, always wear a helmet, suitable protective clothes (long trousers), working gloves and safety shoes!**



**Before commencing to work, make sure that all mechanical and electrical components are properly mounted and/or linked!**

The handling of construction elements is carried out as follows:

- ⇒ Lift the counterweight balancer and move the travelling cage with the help of the buttons “travelling cage forwards” and “travelling cage backwards” until the main girder is balanced. The yellow signal light is illuminated.
- ⇒ Release the wing screw of the stop plate (s. fig. 9) and push the stop plate onto the travelling cage until the front limit switch is triggered. The yellow signal light turns off. Firmly retighten the wing screw.
- ⇒ Move the counterweight balancer to the construction elements by means of the crane.
- ⇒ Couple the construction element to be lifted to the counterweight balancer.
- ⇒ Slightly lift the counterweight balancer including the load and equilibrate the load by moving the counterweights. As soon as the travelling cage is moved away from the stop plate and the front limit switch is not triggered anymore, the yellow signal light is illuminated.
- ⇒ Do not lift the load higher than necessary!
- ⇒ Bring the load into the required position by the driving and lifting movements of the crane as well as by manual guidance of the counterweight balancer.
- ⇒ Place the construction element at its destination in such a way that it does not constitute a threat after the release of the counterweight balancer.
- ⇒ Now release the construction element from the counterweight balancer. To this end, move the travelling cage in the direction of the stop plate until the travelling cage stops itself. The yellow signal light turns off and thus signalizes that the counterweight balancer is equilibrated in a load-free condition. If applicable, lower the counterweight balancer by means of the crane so far that the load hook is not under load while the construction element is detached. This procedure prevents a sudden downward or upward tilting of the main girder while the construction element is detached.



**Always carefully release the counterweight balancer from the construction element. Make sure that the load hook is not under load during detachment and the counterweight balancer is equilibrated! Non-compliance with these instructions can lead to severe injuries.**



## 4 Service and maintenance

### 4.1 General remarks

Since the counterweight balancer is a load lifting attachment, both the manufacturer and the operator bear a high responsibility to guarantee the relevant safety standard throughout the entire operating time. Thus, service and maintenance are of great importance.

For maintaining a high level of operational safety, the counterweight balancer GGA-B 6300/40/3,0/6,0 oVH has to be inspected by the service workshop of Wirth GmbH or by an especially qualified person (expert):

- ⇒ at least every 12 months or in shorter intervals, if this is stipulated by national standards or regulations, or
- ⇒ after specific incidents.

Additional operative and scheduled maintenance and service work may only be performed by a skilled expert.

Maintenance and service work may only be performed when the counterweight balancer is taken out of operation.



**Before performing any repair or maintenance work turn the counterweight balancer off; turn the main switch to position “OFF” and if applicable, disconnect any connected battery charger.**

Defective parts may only be replaced with original spare parts. They will be provided on request after consulting with the service team of the manufacturer of the counterweight balancer. Using non-original spare parts leads to an exemption from liability by the manufacturer.

In order to perform maintenance and service work an appropriate tool kit has to be used.



**Maintenance always has to be followed by a functional check.**

If damages cannot be repaired by the operator's staff, the Wirth GmbH service workshop needs to be informed.

### 4.2 Mechanical system

The mechanical system is sturdy and surface protected. For maintenance perform

- ⇒ prior to start-up, **daily** visual inspection of the mechanical components of the counterweight balancer GGA-B 6300/40/3,0/6,0 oVH for damages.

The counterweight balancer GGA-B 6300/40/3,0/6,0 oVH is a load lifting attachment. Therefore, repairs on the mechanical functioning parts shall be exclusively carried out by the manufacturer.



**Do not perform any repairs at mechanical functioning parts!**



### 4.3 Electrical and electronic components

The counterweight balancer GGA-B 6300/40/3,0/6,0 oVH is powered by maintenance-free lead-gel batteries (acidic). The battery casings are sealed hermetically.

Maintenance work focuses on:

- ⇒ **daily** visual inspection of the external electrical functional and alarming equipment:
  - limit switch of the travelling cage,
  - battery charging socket,
  - charge indicator.
- ⇒ visual inspection of the battery's charge level shown on the charge indicator (s. fig. 5).
- ⇒ charging the battery

For charging the battery a 24 V / 8 A charger is supplied by the manufacturer of the counterweight balancer (s. fig. 10).

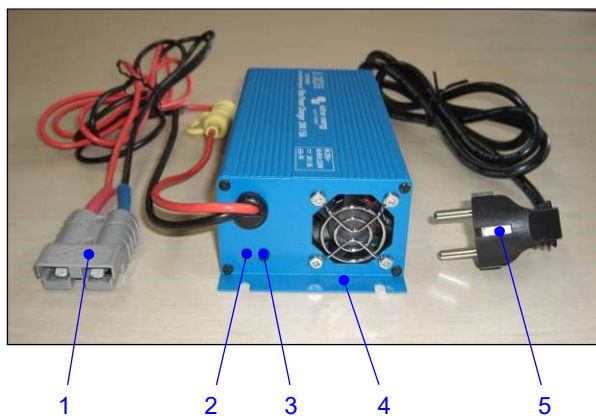

- 1 Charge plug charger
- 2 Yellow LED
- 3 Green LED
- 4 Battery charger
- 5 Mains plug

Fig. 10: Battery charger (example)



**Prior to connecting the charger, check whether it is compatible with your mains grid! The performance data is stipulated on the charger.**



**Please contact the Wirth service team in advance, if you want to use a different charger than the one supplied with the delivery of the counterweight balancer!**

The charging process is performed as follows:

- Turn the counterweight balancer off. Therefor turn the main switch to position "OFF"!
- Connect the charge plug of the charger with the battery charging socket of the counterweight balancer.
- Connect the mains plug of the charger to a power outlet and thus to the mains grid, in order to start the charging process.
- The charging process is completed, when the yellow LED is constantly illuminated.
- Proceed as follows in order to disconnect the charger from the counterweight balancer:
  1. Disconnect the charger from the mains grid,
  2. Disconnect the charger from the battery.

### LED Display

- ⇒ The green LED is illuminated when the charger is connected to the mains grid.
- ⇒ The yellow LED flashes fast during the first charging stage and slower during the second. At the end of the charging cycle the yellow LED is constantly illuminated.

For maintenance and in case of breakdown of the charger, please contact our service department.



**The sealed lead-gel battery requires strict adherence to the charging instructions!**



**In order to avoid damage due to deep discharge, the batteries of the counterweight balancer have to be charged at least every two weeks.**



**The battery charger has to be protected from spray water and has to be set up in a way that the venting slots and the fan are unobstructed and cannot be pierced through by pointed objects.**

## 5 Handling incidents

In case of mechanical and/ or electrical failures, immediately leave the hazardous area. Locate and rectify the cause for the failure. If you cannot remedy the fault, stop operating the counterweight balancer immediately and secure the counterweight balancer against further use.



**In case of faults that cannot be remedied, working with the counterweight balancer shall be stopped immediately. The counterweight balancer has to be secured against further use. Contact the service workshop of Wirth GmbH.**

If the display of the charge indicator is not illuminated when turning the counterweight balancer on, please contact the service workshop of Wirth GmbH immediately.

## 6 Disposal and recycling

For packaging the counterweight balancer materials like wood, cardboard, paper and film are used. These materials shall be recycled according to national regulations.

To dispose the counterweight balancer hand it over to a waste management company. If you have any question, please do not hesitate to contact Wirth GmbH.



**For environmental reasons, hand over the counterweight balancer for disposal to a waste management company being fully aware of and observing the respective national regulations!**